

# LCC Modelling System

## B 00-30 LMS Style platform mounted footbridge

**All drawings are not in scale.  
Some proportions on drawings may differ from reality.**

For additional elements for modification and extension please visit our website at [www.lcut.co.uk](http://www.lcut.co.uk) or email us at [contact@lcut.co.uk](mailto:contact@lcut.co.uk)

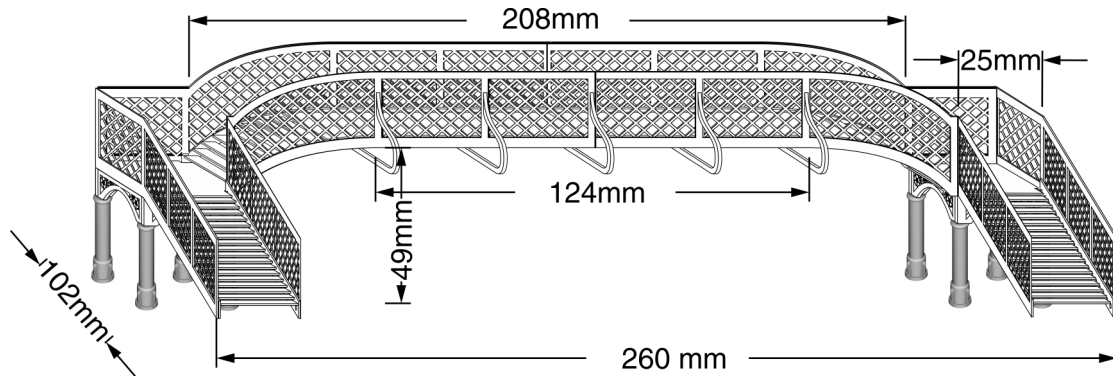

Bundle contains:

- |  |   |
|--|---|
| <ul style="list-style-type: none"> <li>• 2x LCC 00-114</li> <li>• 2x LCC 00-115</li> <li>• 2x LCC 00-116</li> <li>• 5x LCC 00-117</li> </ul> | <ul style="list-style-type: none"> <li>• 2x LCC 00-118</li> <li>• 2x LCC 00-119</li> <li>• 2x LCC 00-120</li> <li>• 2x LCC 00-121</li> <li>• 8x LCC 00-122</li> </ul> |
|--|---|



We recommend PVA or any other paper/wood glue for the main fibre board parts and resin based glue for 3D printed parts if present.

Painting recommendation:

We recommend using acrylic or enamel paints. There is no need to undercoat the surface but it can be done if desired. The material used is porous and relatively forgiving, heavy coats are unlikely to flood the brickwork. If you experience any warping in the material leave it to fully dry and then gently bend it back into shape. Always test any paints in an area that will not be seen or on spare parts/off cuts.

This kit contains parts made from 3D printed photosensitive resin. Care has been taken to make sure they are all clean but if there is any residue it can be wiped off with some IPA or methylated spirit. Do not expose the plastic parts to excessive sunlight before painting to avoid over curing them. Any flashing around bottoms of parts needs to be filed away with a fine file. Everything can be painted with either enamel or acrylic paints. Spray paints can also be used.

### BALUSTRADES

First step in the assembly process is to prepare the balustrades and stair sub assemblies. Make sure to prepare the stairs as well as the stair balustrades mirrored. It is possible to assemble the footbridge with staircases ending on opposite sides. In which case assemble all elements in the same sided version. Both LCC 00-114 and LCC 00-115 have to be joined along the middle line.

#### LCC 00-114

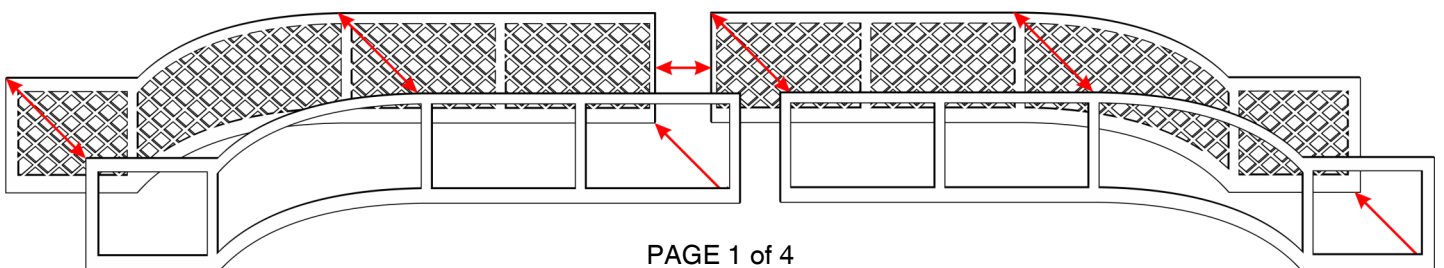

LCC 00-115

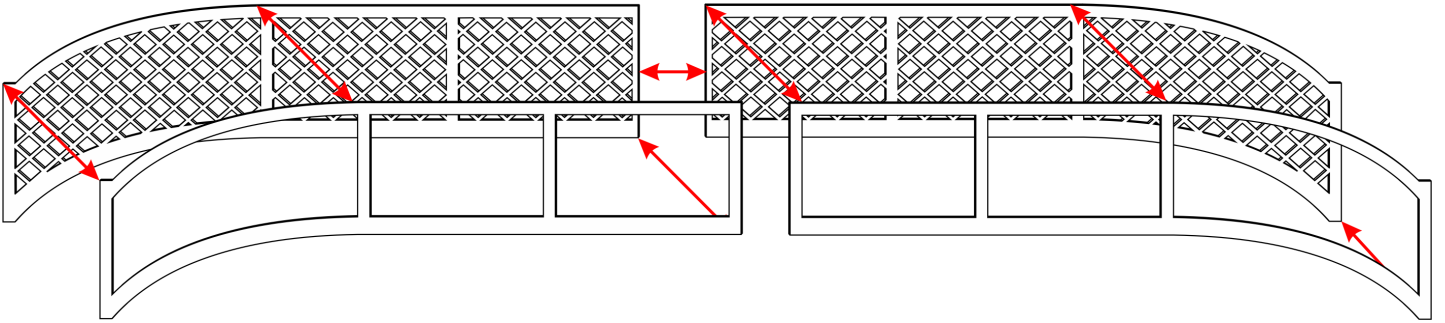

LCC 00-118

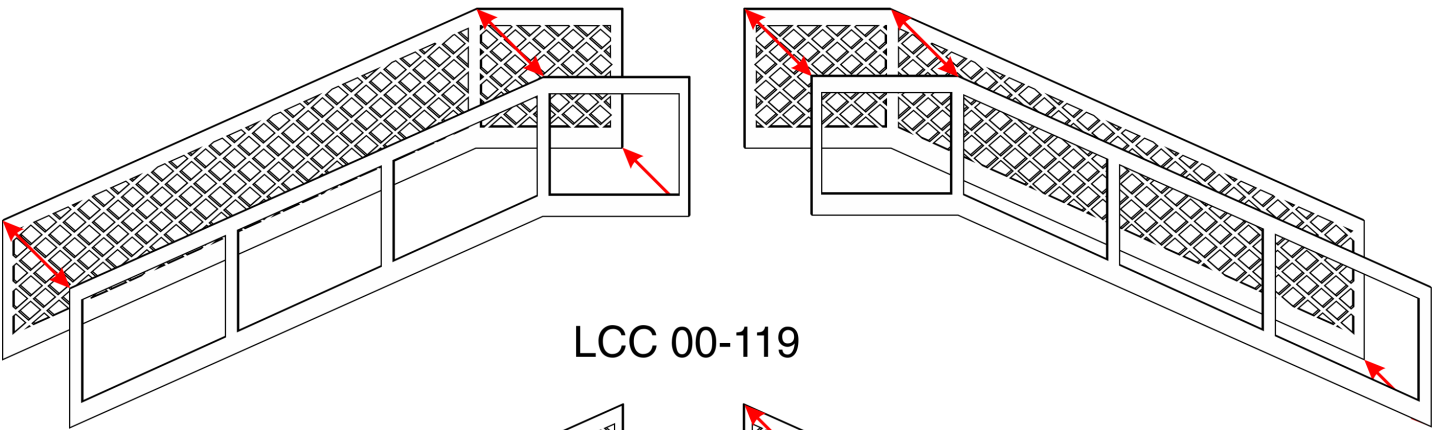

LCC 00-119

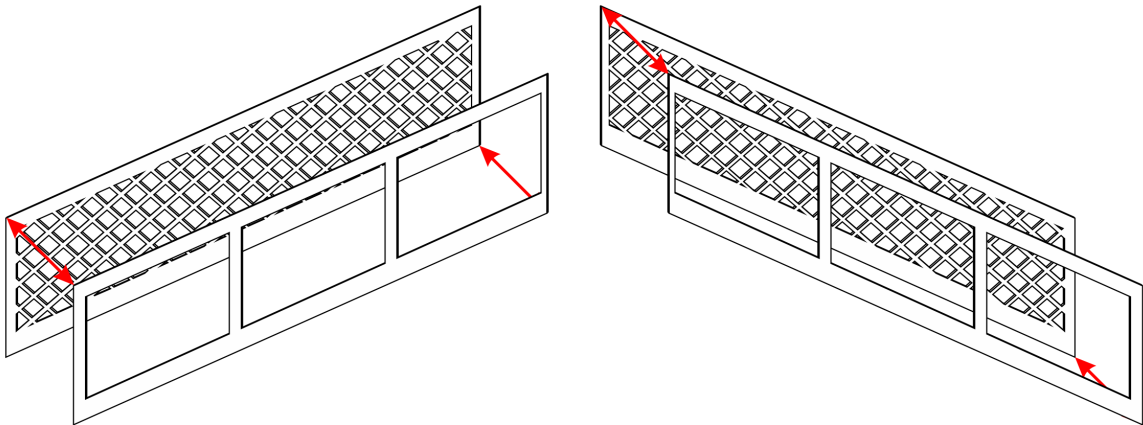

STAIRS

LCC 00-120

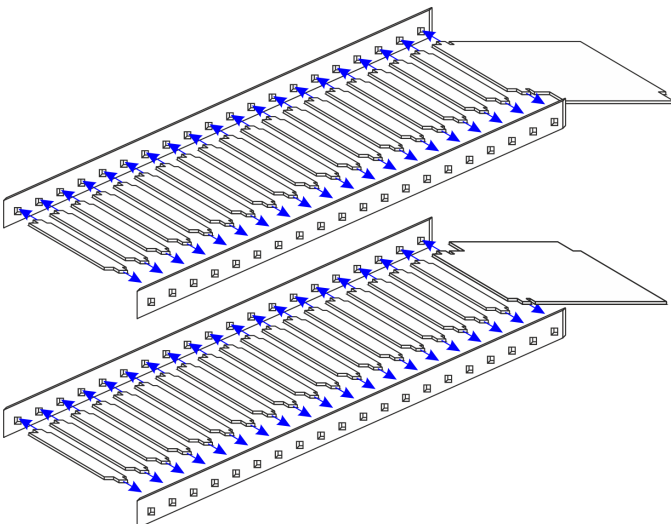

LCC 00-116 (x2)

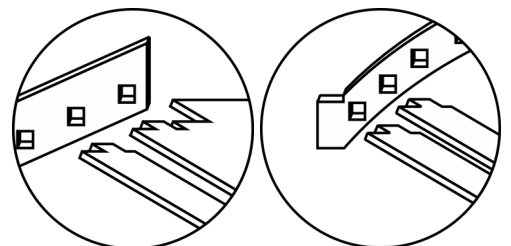
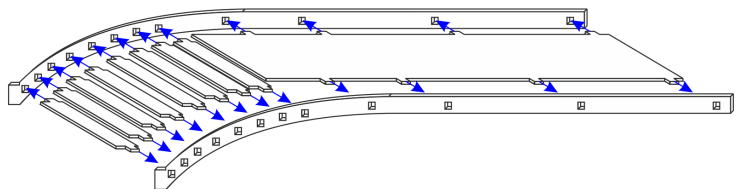

Care needs to be taken when assembling the stairs. Start with LCC 00-116 because they are easier and will help with learning how to do it. Cut out the parts from spruce and clean them up. If needed dry assemble the stairs before gluing them in. Care has been taken to make sure the stairs go into the slots in the railings easily. However that means glue is required for permanent assembly.

It is extremely important to ensure that the steps are glued with the longer protrusion facing forward (or down the slope). Furthermore it is crucial that lower step railings are used in the correct orientation. The length of material above the step holes should be larger above the step than below. Refer to the diagram on previous page for visual aid in positioning. The central span railing can only be assembled in one way but again remember that that steps need to be facing the longer protrusion forward/down slope! Also note that the engraved markings on the middle walkway should be facing down. They will later be used to align balustrade supports.

Next step is to glue the balustrades to the staircases. Use the bottom most edge of the staircase railing to align the balustrade. All of the railings should be flush with the balustrades on their bottom edges. The shorter balustrades for the lower staircases should be glued to the staircases with the thinner baluster on the landing end of the staircase.

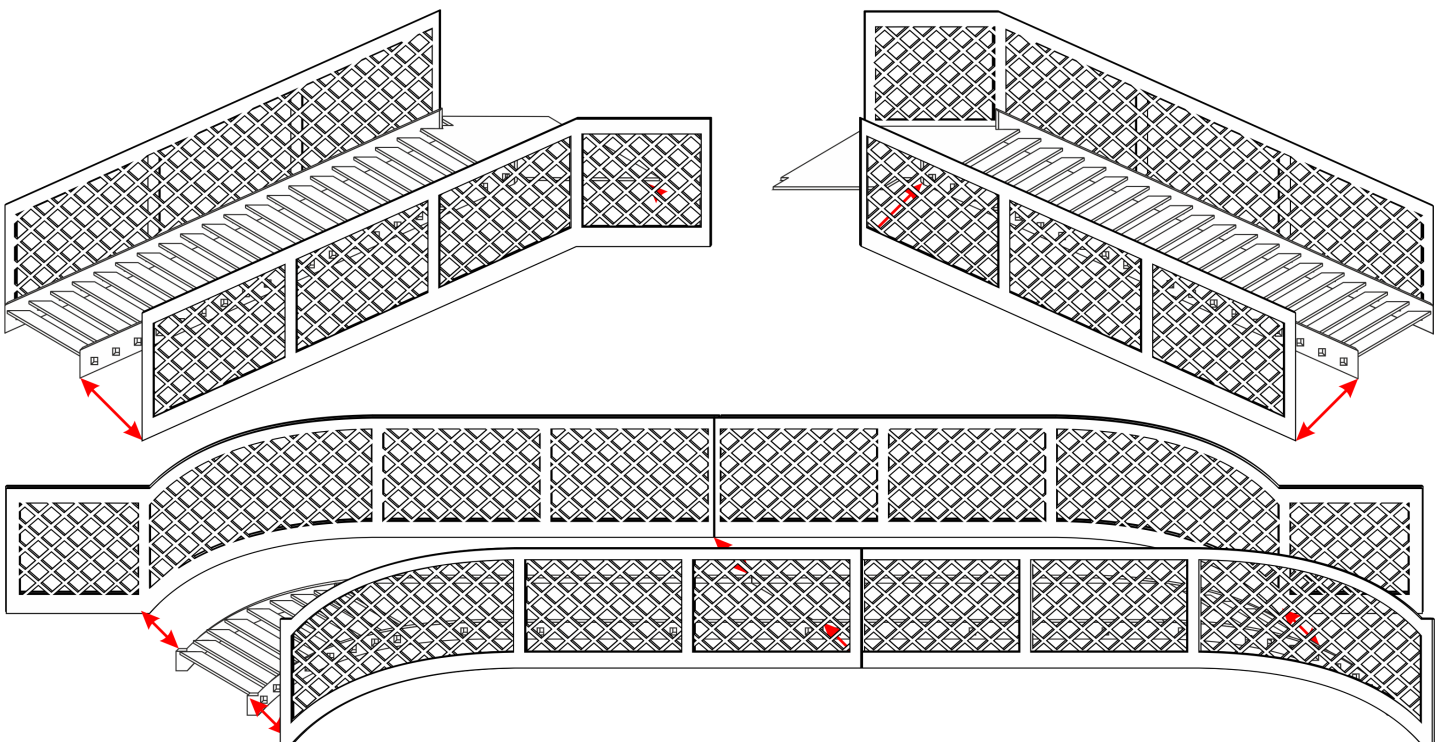

### FINAL ASSEMBLY

After both staircases and the middle span have been assembled it is time to put it all together. Dry fit and practice the assembly before applying glue. General rule of thumb is that the balustrades should come together without gaps and the top edges should be flush with each other. If the landing is slightly crooked it will not be massively detrimental to the final look of the model. However if the railings are assembled with gaps or not flush it will show badly on the finished model.

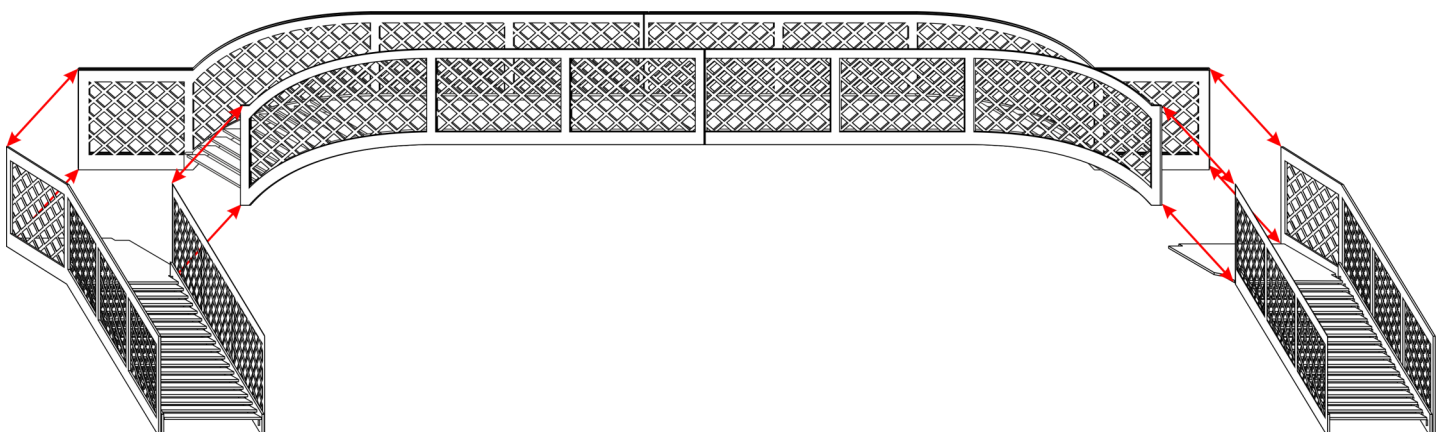

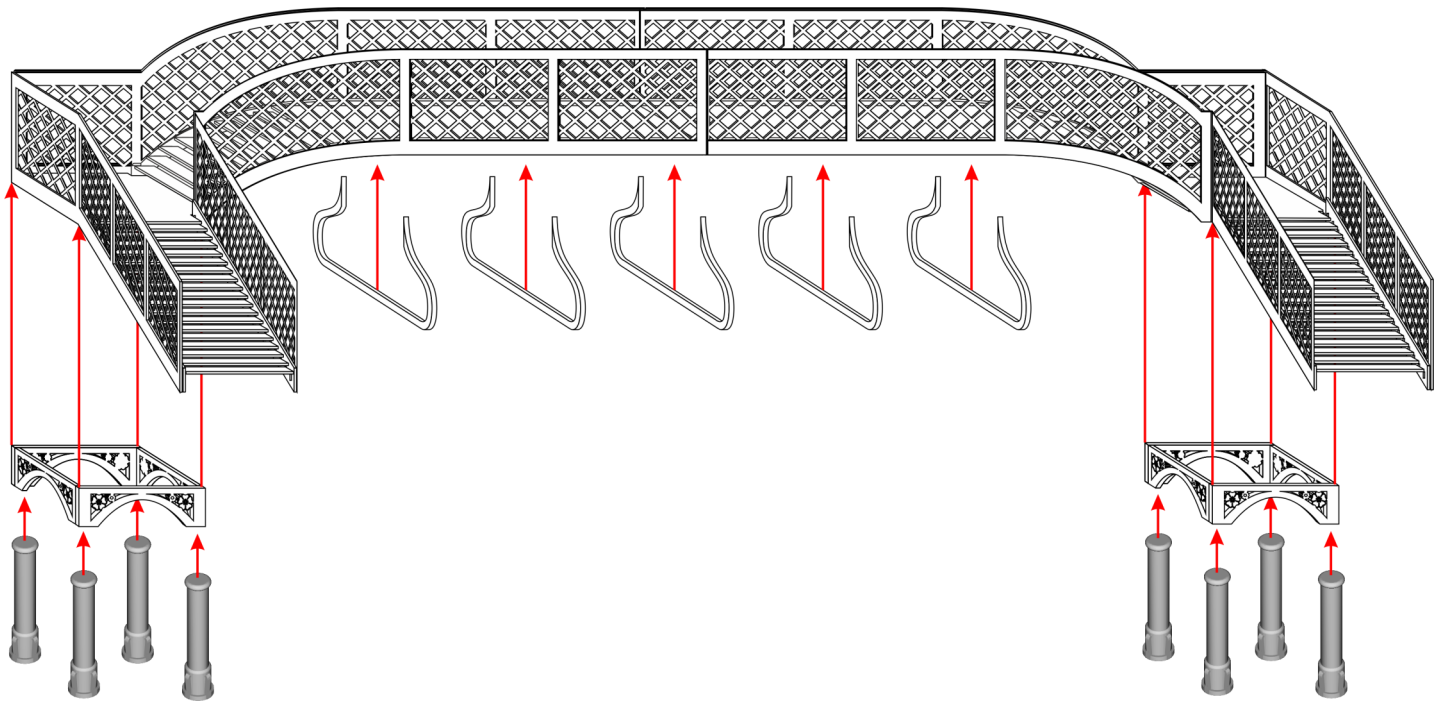

Last steps of the assembly are the balustrade supports, landing arches and the posts.

Start by cutting out all five of the balustrade supports (LCC 00-117). Dry fit the supports by sliding them from under the central span to practice before gluing in place. Balustrade supports should be aligned with the engraved lines on the underside of the middle span as well as the major, thick, balusters on the balustrade. Prototype of the footbridge this model is based on was not fitted with smoke deflectors.

Cut out all of the landing arches from LCC 00-121 spruces. Start by gluing one of the longer ones to the side opposite of the staircase flush with the corners and flush with the balustrade. Glue in the shorter arches perpendicular and then finally finish with the last arch on the staircase side.

Last step is to glue the columns to the arches. Due to how we print them there is a little bit of flashing on the bottom edge of the column. File it away with a fine file or sand paper until the flashing is invisible. The columns are made with photosensitive resin which cannot be exposed to high temperatures or too much UV light. They are reasonably flexible and should not crack easily (do not bend them however). If there are any cracks, voids, or warping/bend in the columns this is a manufacturing fault. We inspect them before packing but there is a possibility a defective column was missed. Please get in touch with us for a replacement if you find a defective column.